

QL2.1-SYSTEM

DE MONTAGEANLEITUNG:
GB ASSEMBLY INSTRUCTIONS:
FR INSTRUCTIONS DE MONTAGE:

IT ISTRUZIONI DI MONTAGGIO:
NL MONTAGE HANDLEIDING:
DK MONTERINGSVEJLEDNING:

ES INSTRUCCIONES DE MONTAJE:
SE MONTERINGS ANVISNING:
NO MONTERINGS ANVISNING:

FI ASENNUSOHJEET:
PL INSTRUKCJA MONTAZU:
JP 換気の良い所に保管してください。



QL2.1 - MODELS

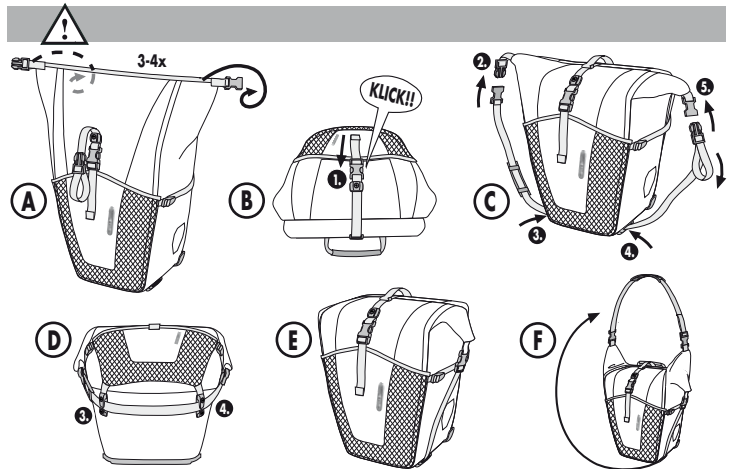

ACCESSOIRES

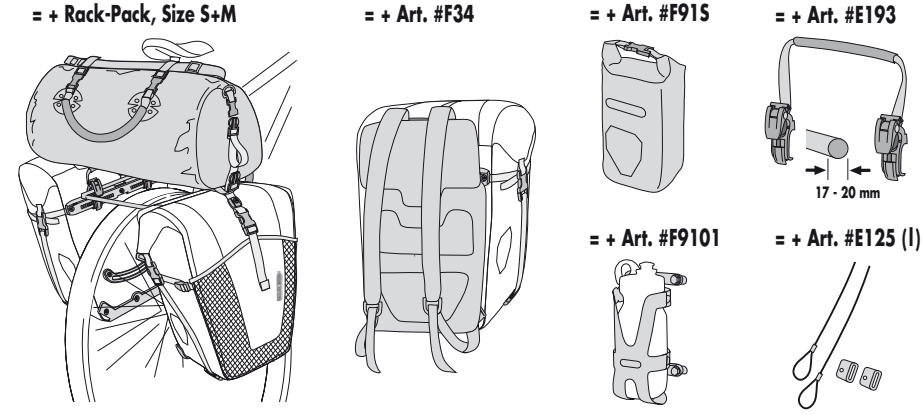

QL2.1

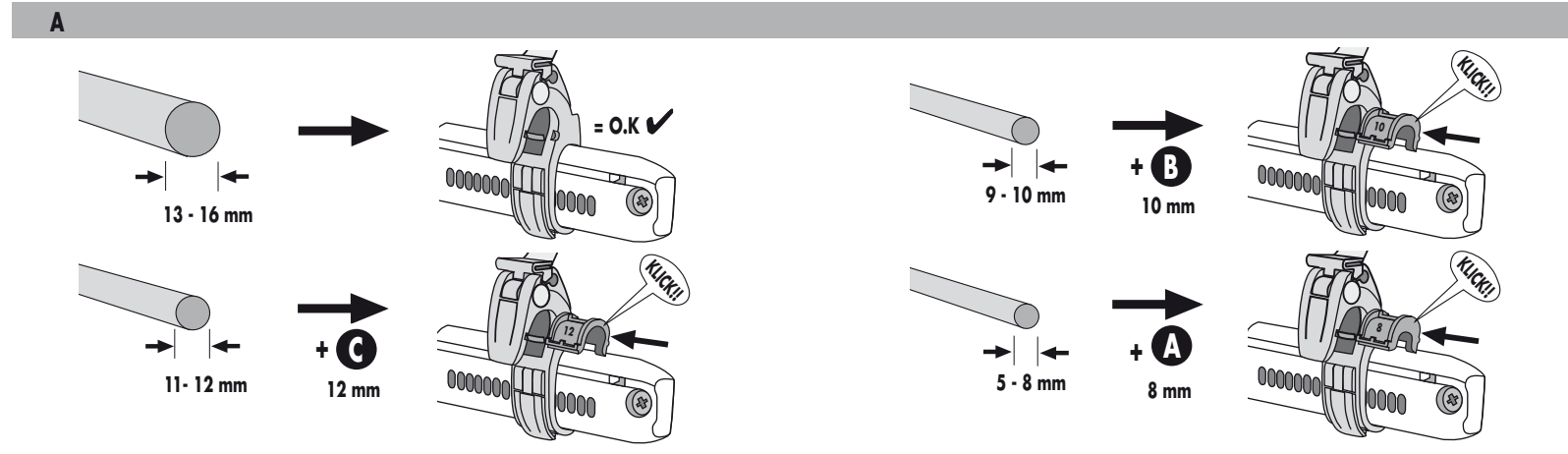
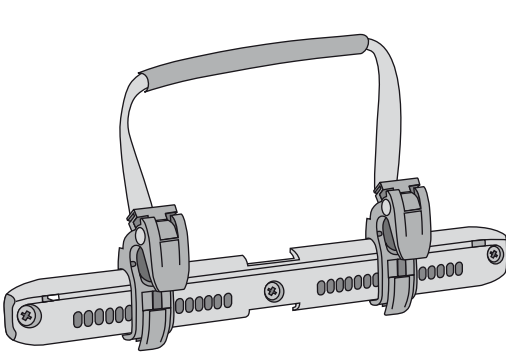

= **A** 8 mm = **B** 10 mm = **C** 12 mm

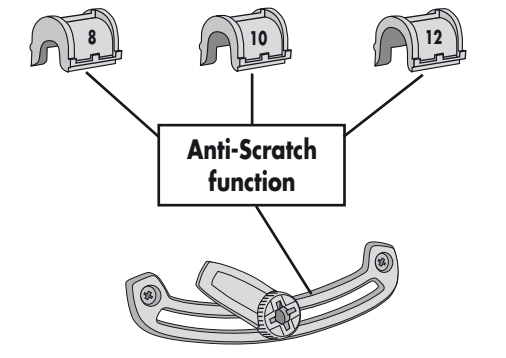

B

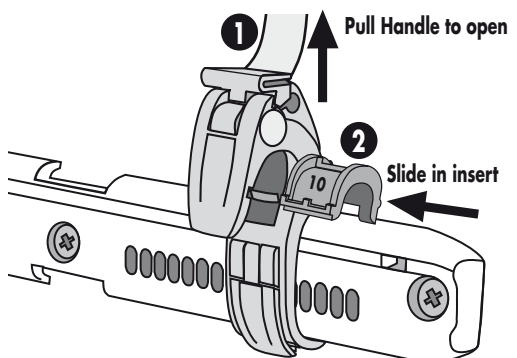

C

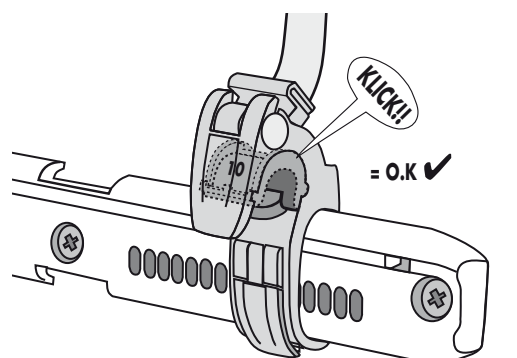

D

